



Z Purlin Brochure Galvanized

Information

Members

The members represented in this publication are typically produced in G60, grade 50 cold formed steel. G90 is available upon request but may require longer lead times.

Documentation

This document is subject to change without notice. Please contact B&M Metals to make sure that you have the latest edition of this document.

Service Holes

Service holes in studs can be punched upon request. In the event that spacing for the service holes is not specified, they will be punched on 3 foot centers. Please contact B&M Metals for custom hole spacing or more details.

Steel Members Disclaimer

Use with product tables, details, and preliminary estimating only

1. Scope / Intended Use

- Reference use only. This brochure is a general product reference for preliminary review, estimating, and coordination. It is not a sealed design package.
- Engineer verification required. All spans, reactions, member adequacy, deflection, stability, bracing, connections, anchorage, and foundation requirements shall be verified by a licensed Professional Engineer in the project jurisdiction.
- Project-specific conditions govern. Final member selection depends on actual loads, unbraced length, end conditions, diaphragm action, serviceability limits, and governing code requirements.

2. Design / Fabrication

- Codes and standards. Verify design using the governing code and applicable standards, including current editions of AISC 360, ASCE/SEI 7, and MBMA references where applicable.
- Material and availability. Dimensions, grades, coatings, lengths, hole patterns, finishes, tolerances, and availability may vary by mill, supplier, and production schedule. Specifications are subject to change without notice.
- Fabrication and field changes. Shop drawings, weld procedures, bolt selection, detailing, substitutions, and field modifications must be reviewed and approved by the Engineer of Record before use.

3. Liability / Revision Control

- No warranty of fitness for design. Listed members and properties are provided without guarantee that they satisfy a specific building, loading case, or code condition.
- Tolerance / liability limitation. Sweep, camber, twist, finish variation, and minor dimensional variation may occur within accepted manufacturing tolerances.
- Confirm latest revision. Verify the latest brochure revision and current project criteria before ordering, engineering, or installation. Contact B&M Metals for updated data or project-specific support.

Suggested Reference Standards

- AISC 360-22 - Structural steel design
- ASCE/SEI 7-22 - Design loads
- MBMA Metal Building Systems Manual - 2024
- Applicable ASTM material specs per project documents

Other Notes

- Member weights and section properties are nominal unless noted otherwise.
- Connection details shown elsewhere are conceptual unless sealed by the Engineer of Record.
- Do not scale drawings. Use written dimensions only.
- Contact B&M Metals for updated data, custom members, or project support.

Steel Members Documentation

Custom Z's

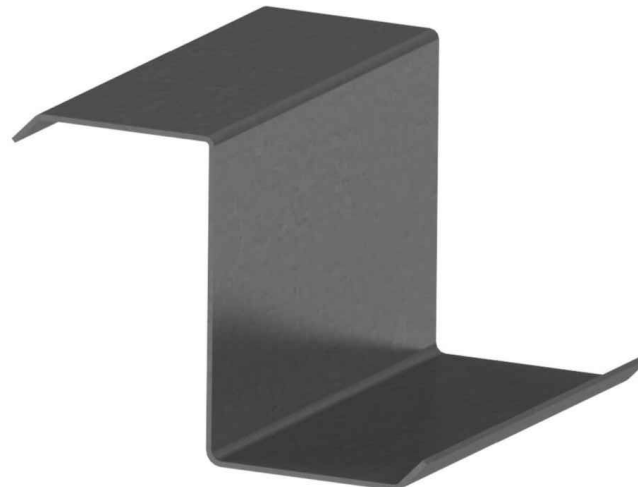
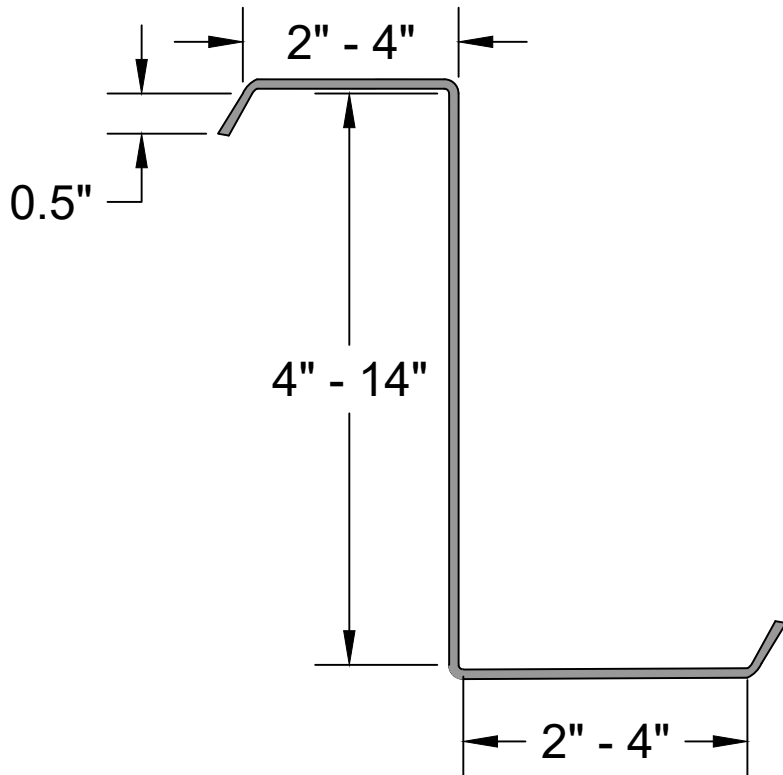

6195 Hwy 52 East
 Murrayville GA, 30564
www.BMMetals.com
 Office: (706) 864-6068
 Fax: (706) 864-2147

Member specs and limits

Name:	DepthZFlange
Depth:	4" - 14"
Flange:	2" - 4"
Lip:	.5"
Lengths:	6' - 60'
Gauges:	16, 14, 12

Name Breakdown

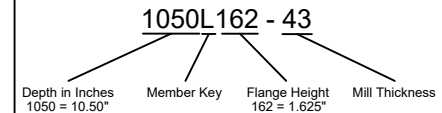

Member Key

- S** = Stud (C Shaped)
- L** = Lintel (L Shaped)
- T** = Track (U Shaped)
- W** = I-Beam (I Shaped)
- E** = Eave Strut (C Shaped)
- D** = Double Eave Strut
- A** = Angle (2 Legs, 1 Angle)
- F** = Hat (Top Hat Shaped)
- B** = Box (Rectangle Shaped)
- Fl** = Strap/Flat (Flat Shaped)
- Z** = Zee (Z Shaped)

Mill - Gauge	Bend Radius
--------------	-------------

25 mill = 24 gauge	.0764
30 mill = 22 gauge	.0796
33 mill = 20 gauge	.0764
43 mill = 18 gauge	.0712
54 mill = 16 gauge	.0849
68 mill = 14 gauge	.1069
97 mill = 12 gauge	.1325

* All members shown in 14 gauge to show detail

CUSTOM_Z_PURLIN

Steel Members Documentation

4" x 2 1/2" Zee

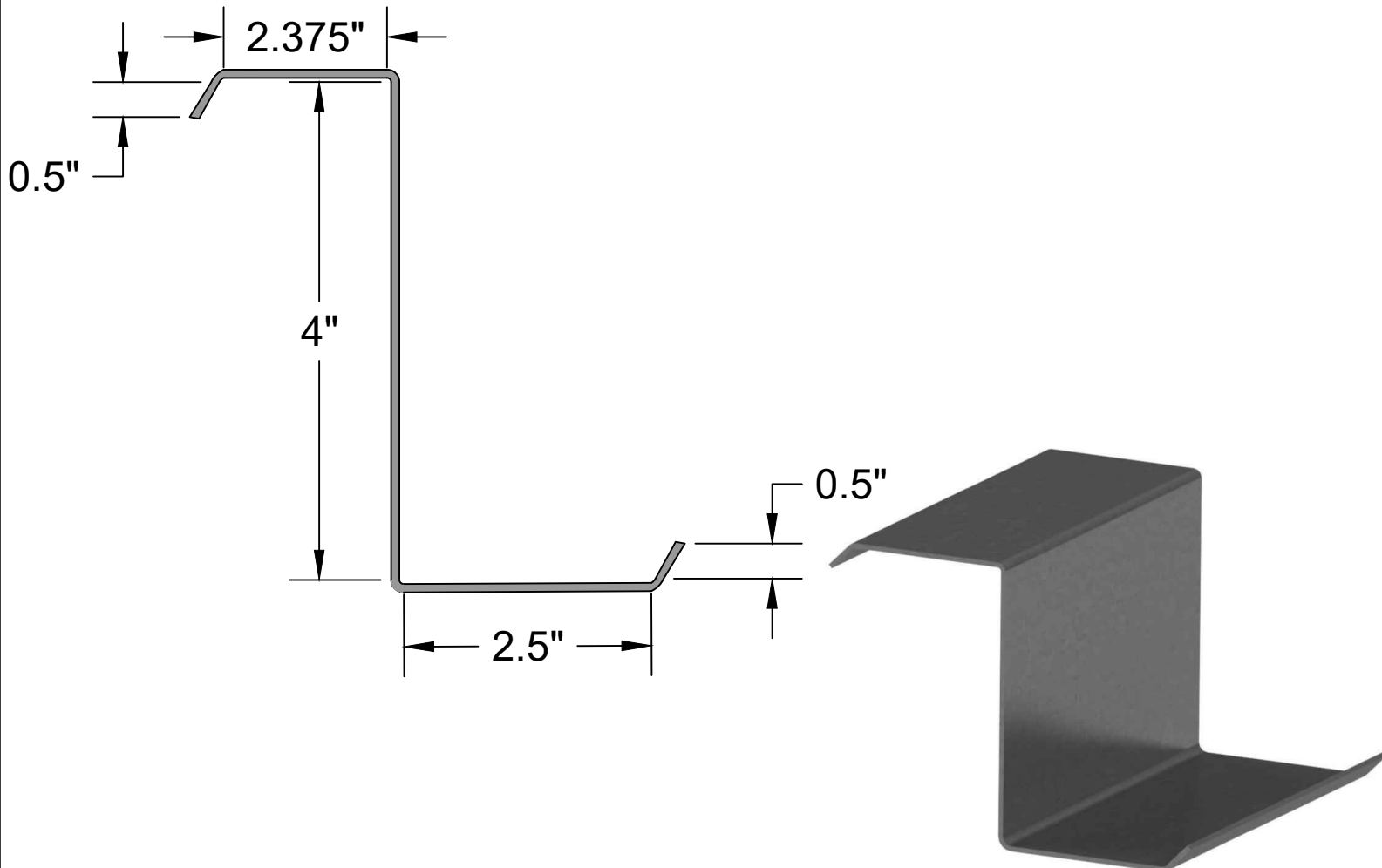

6195 Hwy 52 East
Murrayville GA, 30564
www.BMMetals.com
Office: (706) 864-6068
Fax: (706) 864-2147

Member specs and limits

Name: 400Z250
Depth: 4"
Flange: 2.5"
Lip: .5"
Lengths: 6' - 60'
Gauges: 16, 14, 12

Name Breakdown

1050L162 - 43

Depth in Inches: 1050 = 10.50"
Member Key: L
Flange Height: 162 = 1.625"
Mill Thickness: 43

Member Key

- S = Stud (C Shaped)
- L = Lintel (L Shaped)
- T = Track (U Shaped)
- W = I-Beam (I Shaped)
- E = Eave Strut (C Shaped)
- D = Double Eave Strut
- A = Angle (2 Legs, 1 Angle)
- F = Hat (Top Hat Shaped)
- B = Box (Rectangle Shaped)
- FI = Strap/Flat (Flat Shaped)
- Z = Zee (Z Shaped)

Member Name	G	ksi	Area	Weight	Width	Gross Properties (x)			Gross Properties (y)			Torsional Properties		
						lx	Sx	rx	ly	Sy	ry	J	Cw	Ro
400Z250-54	16	50	0.598	2.035	5.06	1.699	0.850	1.686	1.028	0.406	1.311	0.00071	4.114	2.136
400Z250-68	14	50	0.747	2.542	5.07	2.123	1.061	1.686	1.295	0.510	1.317	0.00139	5.179	2.139
400Z250-97	12	50	1.046	3.559	5.10	2.973	1.486	1.686	1.842	0.720	1.327	0.00382	7.366	2.145

Mill - Gauge	Bend Radius
25 mill = 24 gauge	.0764
30 mill = 22 gauge	.0796
33 mill = 20 gauge	.0764
43 mill = 18 gauge	.0712
54 mill = 16 gauge	.0849
68 mill = 14 gauge	.1069
97 mill = 12 gauge	.1325

400Z250

*All calculations should be verified by licensed Engineer
** Full Sectional properties available upon request

Steel Members Documentation

6" x 2 1/2" Zee

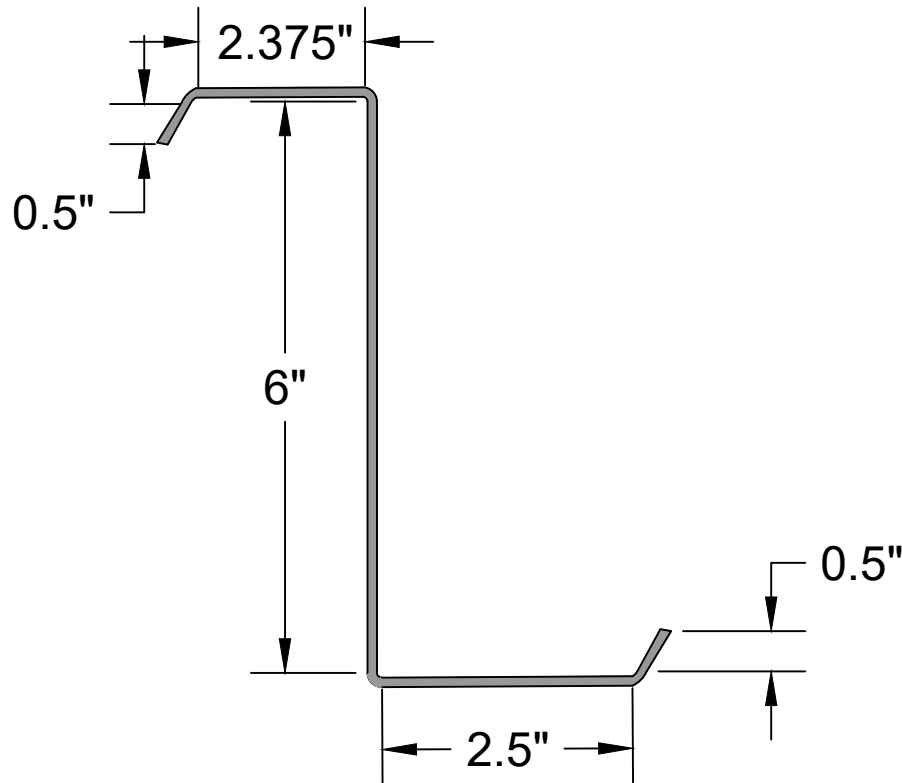

6195 Hwy 52 East
Murrayville GA, 30564
www.BMMetals.com
Office: (706) 864-6068
Fax: (706) 864-2147

Member specs and limits

Name:	600Z250
Depth:	6"
Flange:	2.5"
Lip:	.5"
Lengths:	6' - 60'
Gauges:	16, 14, 12

Name Breakdown

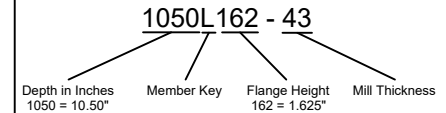

Member Key

- S** = Stud (C Shaped)
- L** = Lintel (L Shaped)
- T** = Track (U Shaped)
- W** = I-Beam (I Shaped)
- E** = Eave Strut (C Shaped)
- D** = Double Eave Strut
- A** = Angle (2 Legs, 1 Angle)
- F** = Hat (Top Hat Shaped)
- B** = Box (Rectangle Shaped)
- FI** = Strap/Flat (Flat Shaped)
- Z** = Zee (Z Shaped)

Member Name	Gross Properties (x)					Gross Properties (y)			Torsional Properties					
	G	ksi	Area	Weight	Width	Ix	Sx	rx	Iy	Sy	ry	J	Cw	Ro
600Z250-54	16	50	0.718	2.442	5.060	4.221	1.407	2.425	1.029	0.406	1.197	0.00086	9.256	2.705
600Z250-68	14	50	0.896	3.050	5.075	5.273	1.758	2.425	1.295	0.510	1.202	0.00167	11.65	2.707
600Z250-97	12	50	1.255	4.271	5.105	7.384	2.461	2.425	1.842	0.720	1.211	0.00458	16.58	2.711

Mill - Gauge	Bend Radius
25 mill = 24 gauge	.0764
30 mill = 22 gauge	.0796
33 mill = 20 gauge	.0764
43 mill = 18 gauge	.0712
54 mill = 16 gauge	.0849
68 mill = 14 gauge	.1069
97 mill = 12 gauge	.1325

600Z250

*All calculations should be verified by licensed Engineer
** Full Sectional properties available upon request

Steel Members Documentation

8" x 2 1/2" Zee

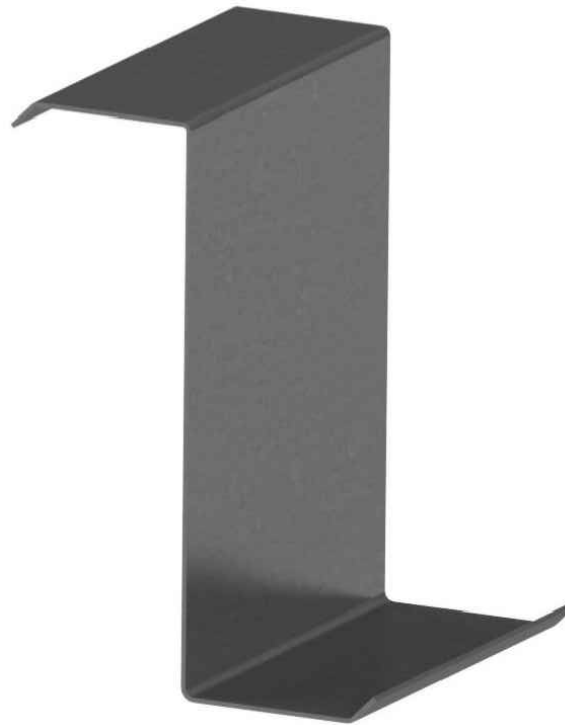
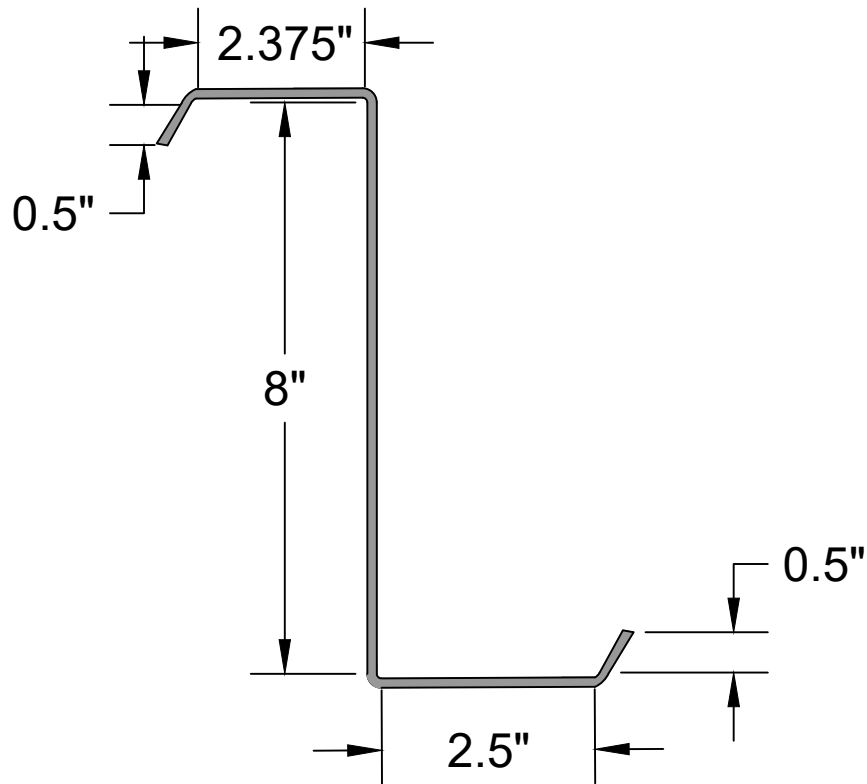

6195 Hwy 52 East
Murrayville GA, 30564
www.BMMetals.com
Office: (706) 864-6068
Fax: (706) 864-2147

Member specs and limits

Name: 800Z250
Depth: 8"
Flange: 2.5"
Lip: .5"
Lengths: 6' - 60'
Gauges: 16,14,12

Name Breakdown

1050L162 - 43

Depth in Inches: 1050 = 10.50"
Member Key: L
Flange Height: 162 = 1.625"
Mill Thickness: 43

Member Key

S = Stud (C Shaped)
L = Lintel (L Shaped)
T = Track (U Shaped)
W = I-Beam (I Shaped)
E = Eave Strut (C Shaped)
D = Double Eave Strut
A = Angle (2 Legs, 1 Angle)
F = Hat (Top Hat Shaped)
B = Box (Rectangle Shaped)
Fl = Strap/Flat (Flat Shaped)
Z = Zee (Z Shaped)

Member Name	G	ksi	Area	Weight	Width	Gross Properties (x)			Gross Properties (y)			Torsional Properties		
						lx	Sx	rx	ly	Sy	ry	J	Cw	Ro
800Z250-54	16	50	0.837	2.849	5.060	8.178	2.044	3.125	1.029	0.406	1.108	0.00100	16.46	3.316
800Z250-68	14	50	1.046	3.559	5.075	10.22	2.554	3.125	1.295	0.510	1.113	0.00195	20.72	3.318
800Z250-97	12	50	1.464	4.983	5.105	14.30	3.576	3.125	1.842	0.721	1.122	0.00534	29.47	3.321

Mill - Gauge	Bend Radius
25 mill = 24 gauge	.0764
30 mill = 22 gauge	.0796
33 mill = 20 gauge	.0764
43 mill = 18 gauge	.0712
54 mill = 16 gauge	.0849
68 mill = 14 gauge	.1069
97 mill = 12 gauge	.1325

800Z250

*All calculations should be verified by licensed Engineer
** Full Sectional properties available upon request

Steel Members Documentation

10" x 2 1/2" Zee

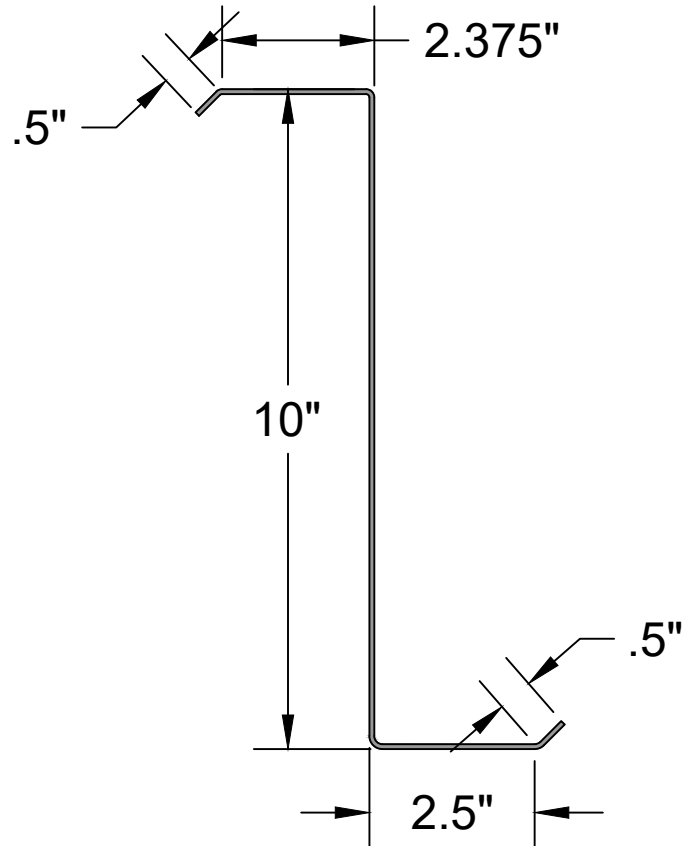

6195 Hwy 52 East
Murrayville GA, 30564
www.BMMetals.com
Office: (706) 864-6068
Fax: (706) 864-2147

Member specs and limits

Name:	1000Z250
Depth:	10"
Flange:	2.5"
Lip:	.5"
Lengths:	6' - 60'
Gauges:	16, 14, 12

Name Breakdown

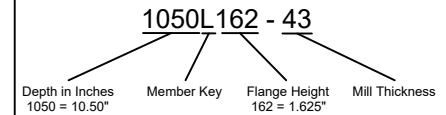

Member Key

- S** = Stud (C Shaped)
- L** = Lintel (L Shaped)
- T** = Track (U Shaped)
- W** = I-Beam (I Shaped)
- E** = Eave Strut (C Shaped)
- D** = Double Eave Strut
- A** = Angle (2 Legs, 1 Angle)
- F** = Hat (Top Hat Shaped)
- B** = Box (Rectangle Shaped)
- FI** = Strap/Flat (Flat Shaped)
- Z** = Zee (Z Shaped)

Member Name	G	ksi	Area	Weight	Width	Gross Properties (x)			Gross Properties (y)			Torsional Properties		
						Ix	Sx	rx	Iy	Sy	ry	J	Cw	Ro
1000Z250-54	16	50	0.957	3.256	5.060	13.81	2.762	3.799	1.029	0.406	1.037	0.00114	25.71	3.938
1000Z250-68	14	50	1.195	4.07	5.075	17.25	3.450	3.799	1.295	0.510	1.041	0.00222	32.37	3.939
1000Z250-97	12	50	1.674	5.695	5.105	24.15	4.831	3.799	1.842	0.721	1.049	0.00610	46.05	3.941

Mill - Gauge	Bend Radius
25 mill = 24 gauge	.0764
30 mill = 22 gauge	.0796
33 mill = 20 gauge	.0764
43 mill = 18 gauge	.0712
54 mill = 16 gauge	.0849
68 mill = 14 gauge	.1069
97 mill = 12 gauge	.1325

1000Z250

*All calculations should be verified by licensed Engineer
** Full Sectional properties available upon request

Steel Members Documentation

12" x 2 1/2" Zee

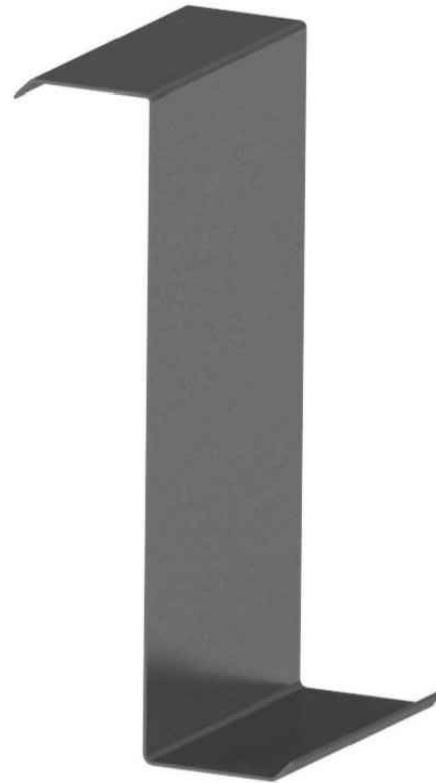
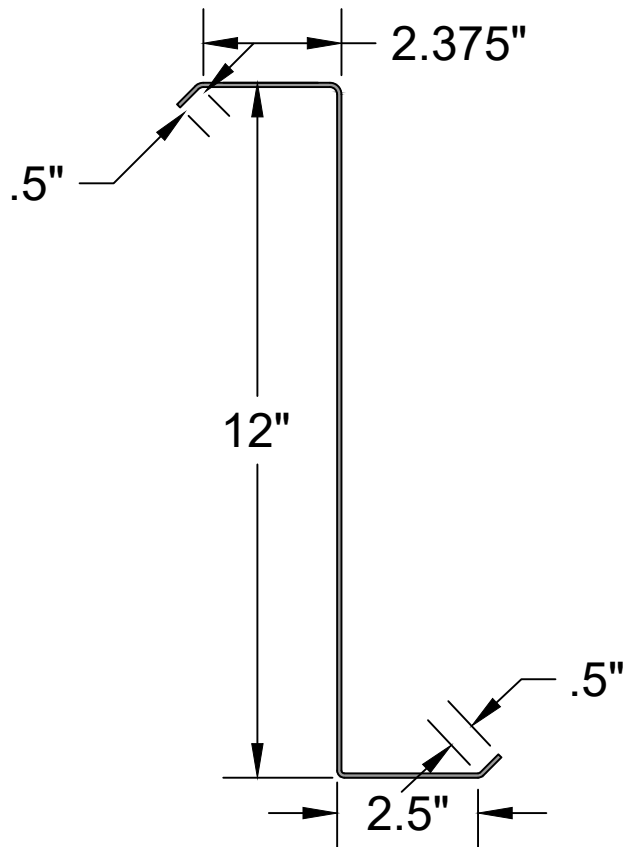

6195 Hwy 52 East
Murrayville GA, 30564
www.BMMetals.com
Office: (706) 864-6068
Fax: (706) 864-2147

Member specs and limits

Name: 1200Z250
Depth: 12"
Flange: 2.5"
Lip: .5"
Lengths: 6' - 60'
Gauges: 16, 14, 12

Name Breakdown

1050L162 - 43

Depth in Inches: 1050 = 10.50"
Member Key: L
Flange Height: 162 = 1.625"
Mill Thickness: 43

Member Key

S = Stud (C Shaped)
L = Lintel (L Shaped)
T = Track (U Shaped)
W = I-Beam (I Shaped)
E = Eave Strut (C Shaped)
D = Double Eave Strut
A = Angle (2 Legs, 1 Angle)
F = Hat (Top Hat Shaped)
B = Box (Rectangle Shaped)
FI = Strap/Flat (Flat Shaped)
Z = Zee (Z Shaped)

Member Name	G	ksi	Area	Weight	Width	Gross Properties (x)			Gross Properties (y)			Torsional Properties		
						I _x	S _x	r _x	I _y	S _y	r _y	J	C _w	R _o
1200Z250-54	16	50	1.076	3.663	5.060	21.35	3.559	4.454	1.029	0.406	0.978	0.00128	37.03	4.560
1200Z250-68	14	50	1.345	4.575	5.075	26.67	4.446	4.454	1.295	0.510	0.981	0.00250	46.62	4.561
1200Z250-97	12	50	1.883	6.407	5.105	37.35	6.225	4.454	1.842	0.721	0.989	0.00687	66.32	4.563

Mill - Gauge	Bend Radius
25 mill = 24 gauge	.0764
30 mill = 22 gauge	.0796
33 mill = 20 gauge	.0764
43 mill = 18 gauge	.0712
54 mill = 16 gauge	.0849
68 mill = 14 gauge	.1069
97 mill = 12 gauge	.1325

1200Z250

*All calculations should be verified by licensed Engineer
** Full Sectional properties available upon request

Steel Members Documentation

14" x 2 1/2" Zee

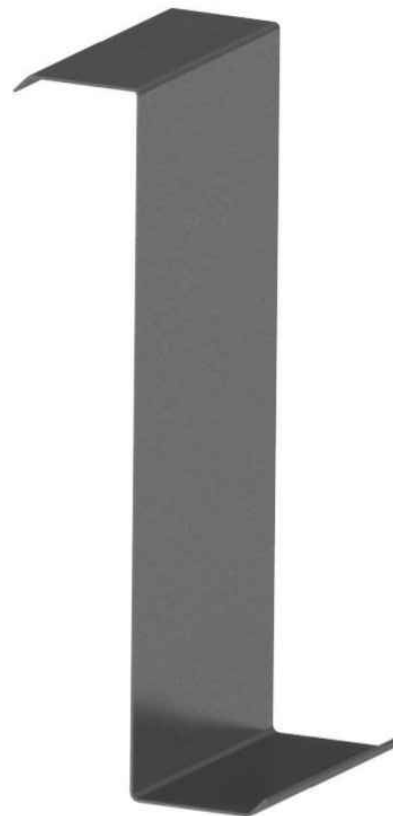
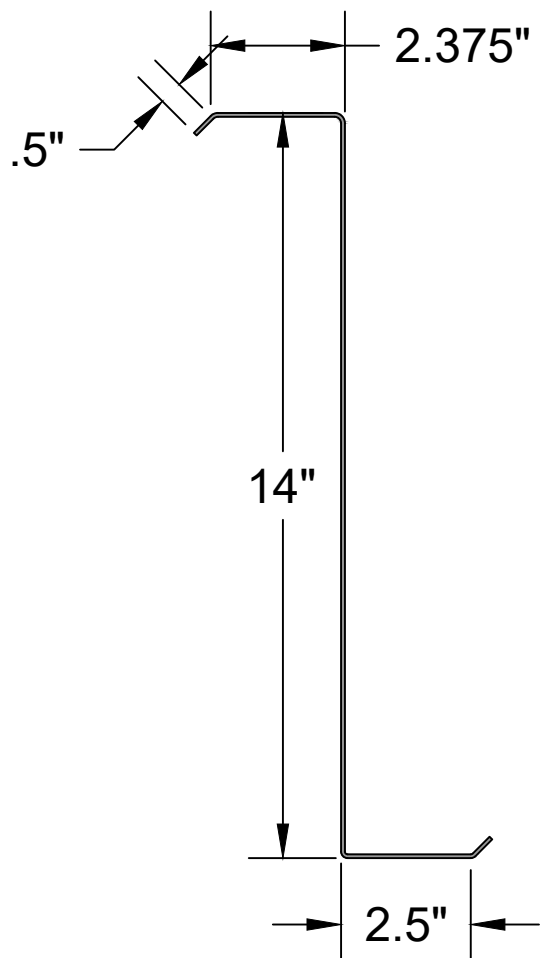

6195 Hwy 52 East
Murrayville GA, 30564
www.BMMetals.com
Office: (706) 864-6068
Fax: (706) 864-2147

Member specs and limits

Name: 1400Z250
Depth: 14"
Flange: 2.5"
Lip: .5"
Lengths: 6' - 60'
Gauges: 16,14,12

Name Breakdown

1050L162 - 43

Depth in Inches: 1050 = 10.50"
Member Key: L
Flange Height: 162 = 1.625"
Mill Thickness: 43

Member Key

S = Stud (C Shaped)
L = Lintel (L Shaped)
T = Track (U Shaped)
W = I-Beam (I Shaped)
E = Eave Strut (C Shaped)
D = Double Eave Strut
A = Angle (2 Legs, 1 Angle)
F = Hat (Top Hat Shaped)
B = Box (Rectangle Shaped)
Fl = Strap/Flat (Flat Shaped)
Z = Zee (Z Shaped)

Member Name	G	ksi	Area	Weight	Width	Gross Properties (x)			Gross Properties (y)			Torsional Properties		
						Ix	Sx	rx	Iy	Sy	ry	J	Cw	Ro
1400Z250-54	16	50	1.196	4.070	5.060	31.05	4.436	5.095	1.029	0.406	0.927	0.00143	50.40	5.179
1400Z250-68	14	50	1.494	5.084	5.075	38.79	5.541	5.095	1.295	0.510	0.931	0.00278	63.46	5.180
1400Z250-97	12	50	2.092	7.119	5.105	54.31	7.759	5.095	1.843	0.721	0.939	0.00763	90.28	5.181

Mill - Gauge	Bend Radius
25 mill = 24 gauge	.0764
30 mill = 22 gauge	.0796
33 mill = 20 gauge	.0764
43 mill = 18 gauge	.0712
54 mill = 16 gauge	.0849
68 mill = 14 gauge	.1069
97 mill = 12 gauge	.1325

1400Z250

*All calculations should be verified by licensed Engineer
** Full Sectional properties available upon request