

self-storage 650

The **650 Series** from Janus International is ideal for light-duty use in carports, barns, sheds and self-storage/commercial unit mix. Janus' industry-leading 3rd Generation roll-up doors are manufactured to be durable and easy to install with little maintenance required.



Maximum
10' x 10'

Available in sizes up to 10' x 10' and in more than 30 colors, customized for your application.



**Self-Storage/
Light-Duty**

Ideal for storage within carports, barns, sheds and self-storage/commercial unit mix.



**Quality
Guaranteed**

Three-year door warranty. For paint, 35-year no-fade, 40-year film integrity.



Features

- » **Pre-Lubricated Springs**
During production, springs are factory lubricated and enclosed in a tube to protect them from the environmental elements.
- » **Dead Axle & Barrel Assembly**
An enclosed spiral barrel houses the dead axle assembly and offers durability and smoother operation as weight is distributed throughout the barrel.
- » **Ratchet Tensioning Device**
Allows you to simultaneously fine tune springs due to the eight different positions on the tension wheel, which provides equal pull on the left and right sides to ensure balanced operation of the door.
- » **26-Gauge Corrugated Door Curtain**
Manufactured from galvanized grade 80 steel and coated with super durable polyester paint in more than 30 color options.
- » **Insulated Version Available**
Side and top draft stops included.

All **DRUMS** are fitted with a grease filled, shielded radial ball bearing to contribute to a smoother operation and reduce wear and friction.

Factory installed galvanized reinforced 16-gauge **BRACKETS** (12-gauge for doors over 9' wide or 8' tall) are designed to easily bolt or snap onto the guides, reducing installation time.

Galvanized, guide-mounted **HEAD STOPS** are simple to install and prevent curtain over travel when raising the door. Installed through guide after curtain is lowered, they provide definite contact with the bottom bar angle and stop clips.

The **RATCHET SPRING TENSIONER ASSEMBLY** is factory installed on the tension end of of door assembly for easy tension/spring adjustment. Increments of 1/8" turn are possible. Tensioner adjusts both springs equally at the same time from only one end of the door.

Roll formed clear acrylic coated galvanized steel **BOTTOM BAR** reinforced with a 1-1/2" x 1-1/2" x 14-gauge full width galvanized angle that extends fully into the guides. The PVC bulb astragal provides positive contact with floor. Lift handle(s) installed on exterior side of bottom bar with interior stop clips and a non-rotting pull rope is attached to the inside angle.

Oil-tempered helical torsion **SPRINGS** are factory lubricated to minimize friction and corrosion while increasing the spring cycle life. Spring wire conforms to ASTM A 229.

Full width galvanized steel **BARREL** totally encloses the drums, springs and axle. Barrel-type construction reduces door sag, eliminates drum dents and improves operation due to an even support of the curtain for the entire width.

Galvanized and pre-painted with long lasting Super Durable polyester paint, the 26-gauge **CORRUGATED CURTAIN** is roll formed from ASTM A 653 grade 80 steel. This premium steel yields greater door strength and minimized curtain damage. Full height felt tape on inside of curtain prevents nesting and reduces paint rubbing. Available in sizes up to 10'0" x 10'0" and in over 30 different colors.

Roll formed, 18-gauge galvanized **GUIDES** are fitted with dual polyethylene wear strips to reduce friction and muffle door noises. All guide attachment to jamb is performed through the guides without the addition of clips welded to the back of the guide. This gives a neater appearance, increased strength and aids in tight installations.

Yellow zinc coated steel or optional stainless steel 4-bolt latch factory installed. The slide exhibits magnetic properties that can be used to activate a guide mounted security sensor. **LATCH** accepts all industry padlocks, including 7/16" diameter shanks. Provision for cylinder lock included.

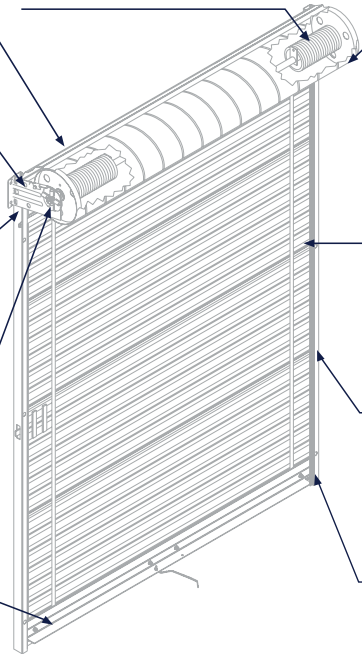

SPECIFICATIONS

Head Room Requirements

Opening Height	Vertical Headroom	Horizontal Headroom
Thru 7'4"	15-1/2"	17"
Over 7'4" thru 8'8"	16"	17-1/2"
Over 8'8" thru 10'0"	17"	18-1/2"

Side Room Requirements

To Outside of Bracket Leg (both ends)	To End of Axle (both ends)
3-1/2"	3-1/2"

HIGHLIGHTS:

- B** Barrel: 9-1/2"
- G** Guide: 2", 18-gauge

Visit JanusIntl.com for technical drawings, color options and more.

Guide Details

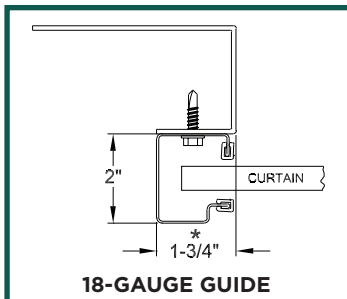

Universal mount 2" deep, 18-gauge galvanized steel guides require no pre-installation modifications for wood, steel, concrete or filled masonry block applications.

2024-02

HEADQUARTERS

Janus International Group
135 Janus International Blvd.
Temple, GA 30179

PLEASE VISIT OUR WEBSITE FOR ADDITIONAL INFORMATION:

- ADA Compliance
- Color Options
- Installation
- Technical Drawings
- Warranty
- Additional Locations

866-562-2580
marketing@janusintl.com
JanusIntl.com