

1 1/2" Nail-Strip

Product Data

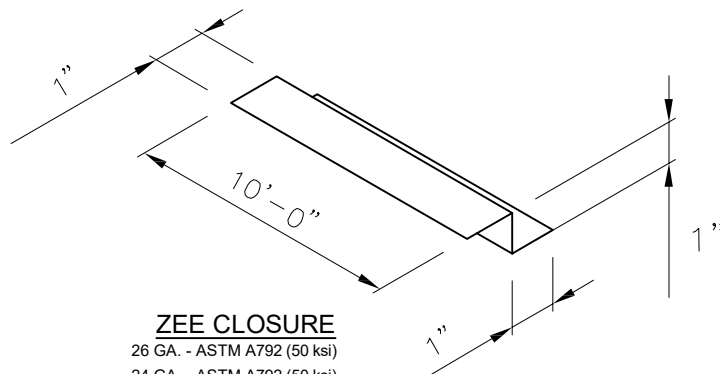
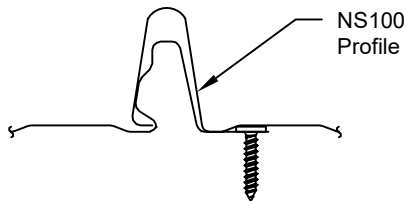
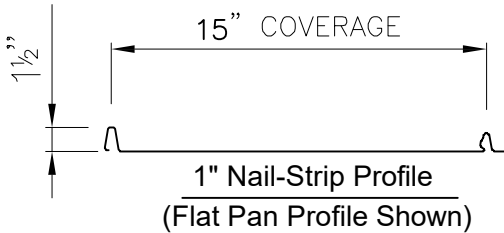

Applications

Snap Seamed roof panel used on slopes down to 3:12. Standard panel lengths up to 50'. Please inquire for longer lengths.

Substrates

Plywood or Rigid Insulation/Metal Deck.

Material

Standard - 24 GA. or 26 GA. ASTM A792 (50 ksi steel)
AZ55 - Bare, AZ50 - Painted

Manufacturing

Roll formed in factory.

Finishes

Acrylic Coated Galvalume®
Fluoropolymer (Kynar 500® PVDF resin-based)

Pan Conditions

16" Minor Rib or Striated - 24 or 26 ga.

16" Flat Pan - 24 or 26 ga.

Oil canning is inherent in all metal panels and is not cause for panel rejection. A signed oil canning acknowledgement will be required for all orders prior to production.

NOTE:

All data represented on this sheet may not be applicable to all widths and gauges.